

DATA SHEET

U 5.201 O₂-PACK ROTARY VANE- VACUUM PUMPS

oil-lubricated

air-cooled

MAKE IT BECKER.

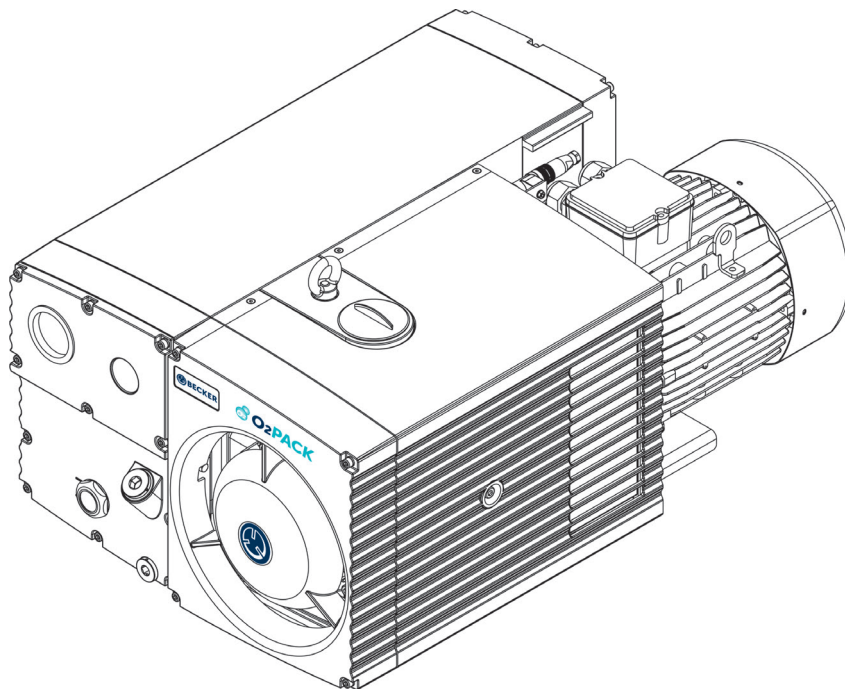

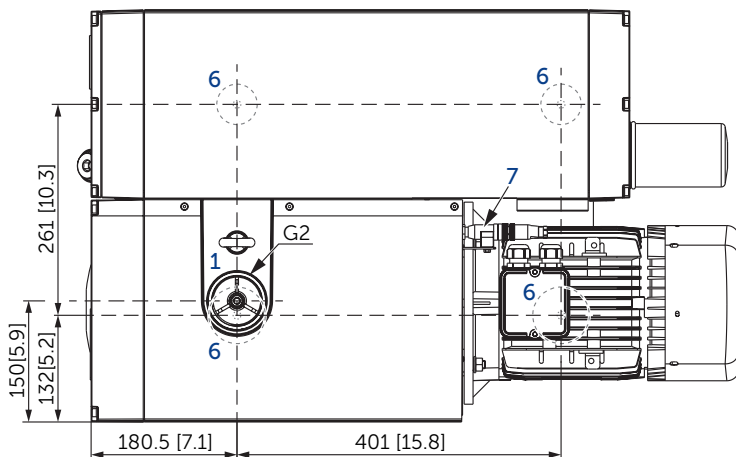
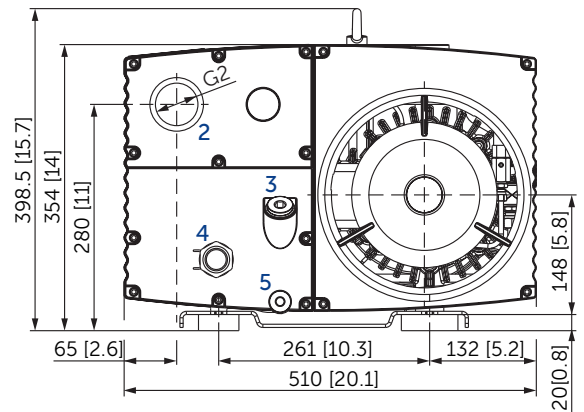
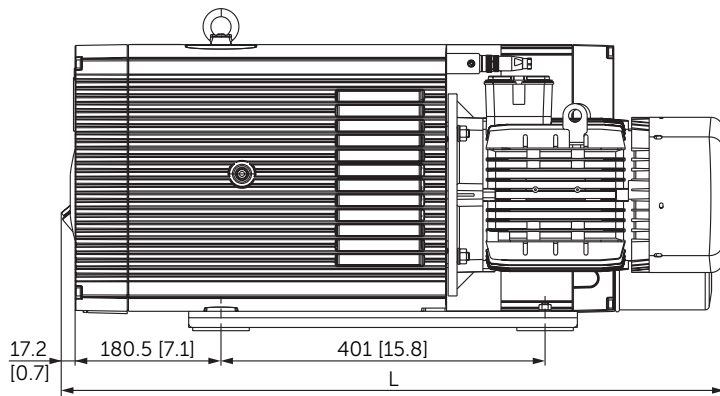

- 1 Vacuum connection (G2)
- 2 Exhaust air connection (G2)
- 3 Oil filler cap (G³/₄)
- 4 Oil sight glass (G1)
- 5 Screw plug for oil drain (G¹/₂)
- 6 Rubber buffer position
 - incl. gas ballast valve, non-return valve, oil separator and oil filter
 - The motor illustration may vary
 - Dimensions in mm [inch]

Nominal capacity		Vacuum absolute for continuous operation		Emission sound pressure level ¹⁾		Weight incl. motor	Oil Fomblin® YL VAC 25/6	L
m ³ /h		mbar		dB(A)		kg	l	mm [inch]
50 Hz	60 Hz	50 Hz	60 Hz	50 Hz	60 Hz			
200	240	<0.5-100	<0.5-100	72	74	143	5 (9.5 kg)	854 [33.6]

3~ Motors											
#	50 Hz					60 Hz					Version
	kW	V	rpm	A	kW	V	rpm	A			
01	4.0	Δ230/Y400	IE3	1465	15.6/9.0	4.8	Δ265/Y460 Δ230/Y400	IE3	1760 - 1747	15.2/8.8 15.9/9.2	UL (E365362) • CSA IP 55 • ISO F • bimetal
02	4.0	YY200/Y400	IE3	1465	18.0/9.0	4.5	YY230/Y460 YY208	IE3 IE3	1759 1753	18.4/9.2 18.7	UL (E235514) • CSA CC329B IP 55 • ISO F • bimetal
03	4.0	Δ200/Y350	-	1467	20.3/11.7	4.5	Δ200/Y380-400 Δ200/Y350	IE3 -	1760 1753	18.5/10.7-10.2 19.0/11.0	UL (E235514) • CSA CC329B IP 55 • ISO F • bimetal
04						4.5	Δ400/Y690	IE3	1763	9.8/5.65	UL (E235514) • CSA CC329B IP 55 • ISO F • bimetal

¹⁾ According to DIN EN ISO 11203, accuracy class of measurement: class 2, extended measurement uncertainty: 3 dB
 1 m [39.4 inch] distance, at medium load, both connection sides piped
 ▪ Gas ballast valve: water vapour tolerance max. 7 mbar; water vapour capacity max. 0.3 l/h (at 85°C operating temperature)
 ▪ Current consumption and rotation speed may vary. Tolerance in each case -1.5/+2%

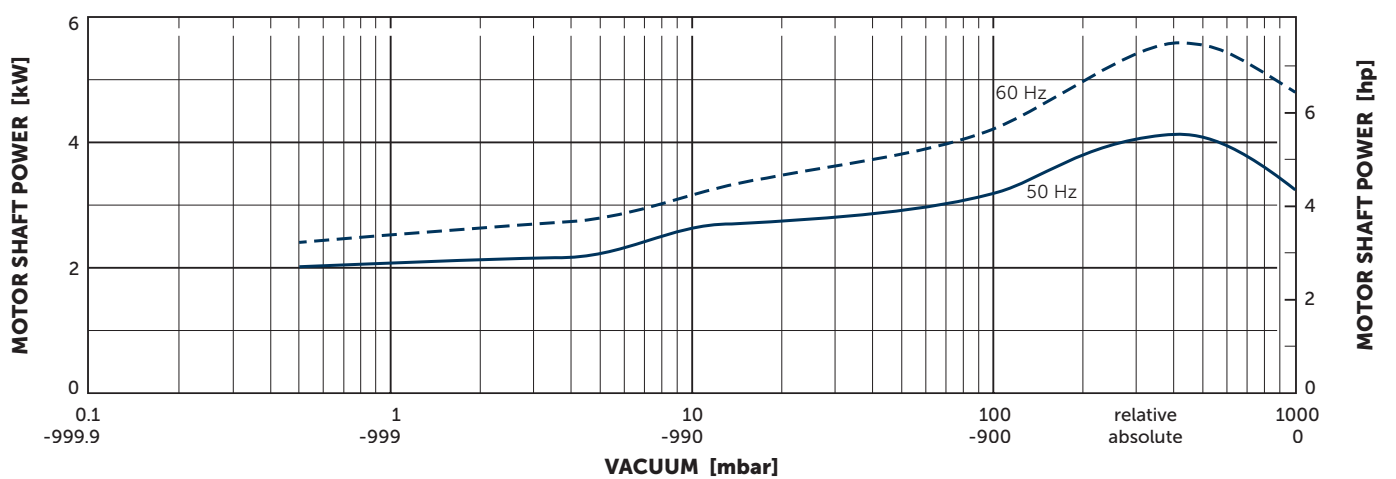
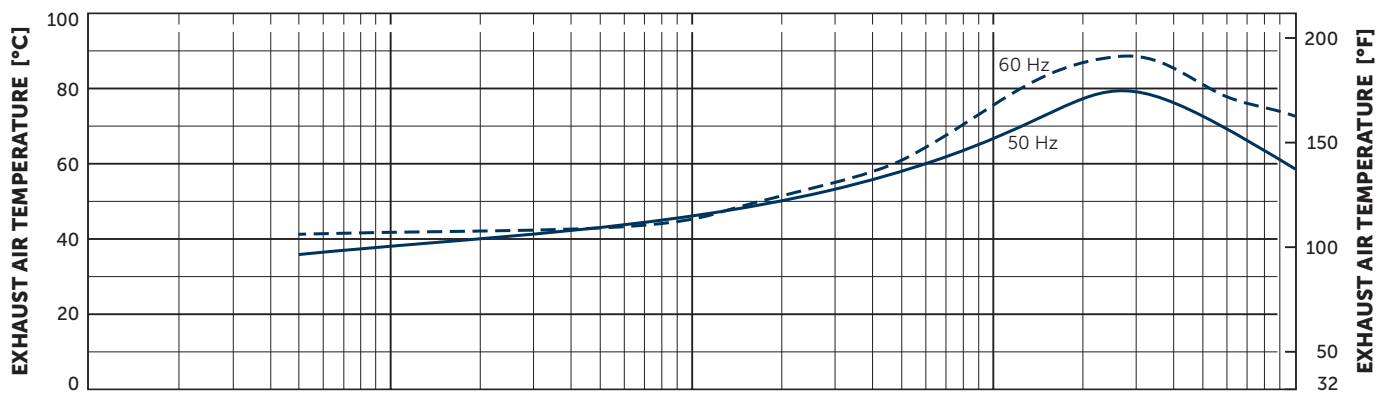
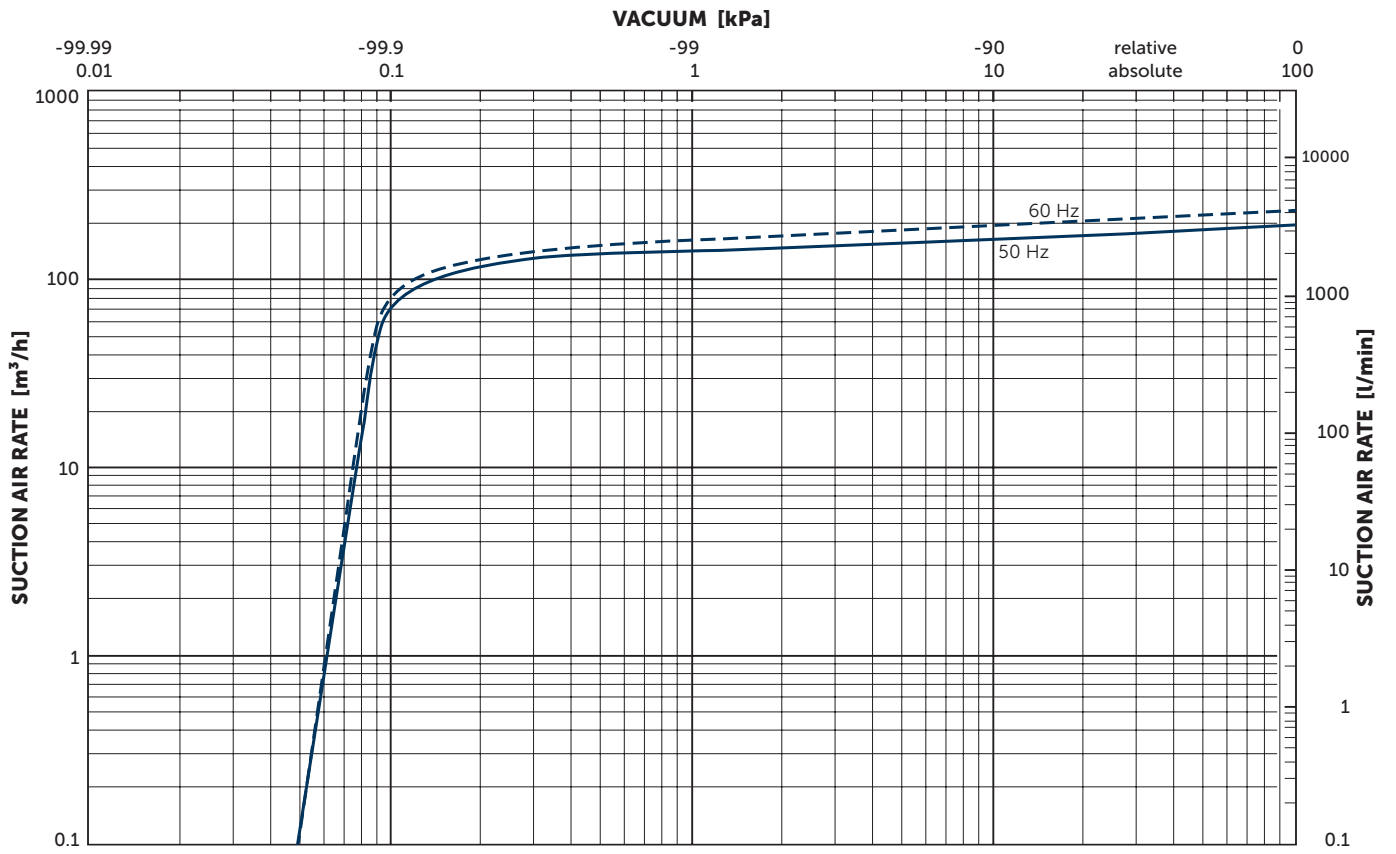

Suction air rate refers to the intake pressure
 Reference data (atmosphere): 1000 mbar (100 kPa), 20°C (68°F)
 Tolerance: ±10%



MAKE IT BECKER.