

DATA SHEET

VARIAIR SV 700/1 SIDE CHANNEL VACUUM PUMPS

single stage, air-cooled
frequency inverter

MAKE IT BECKER.



VARIAIR
UNIT

 **BECKER**

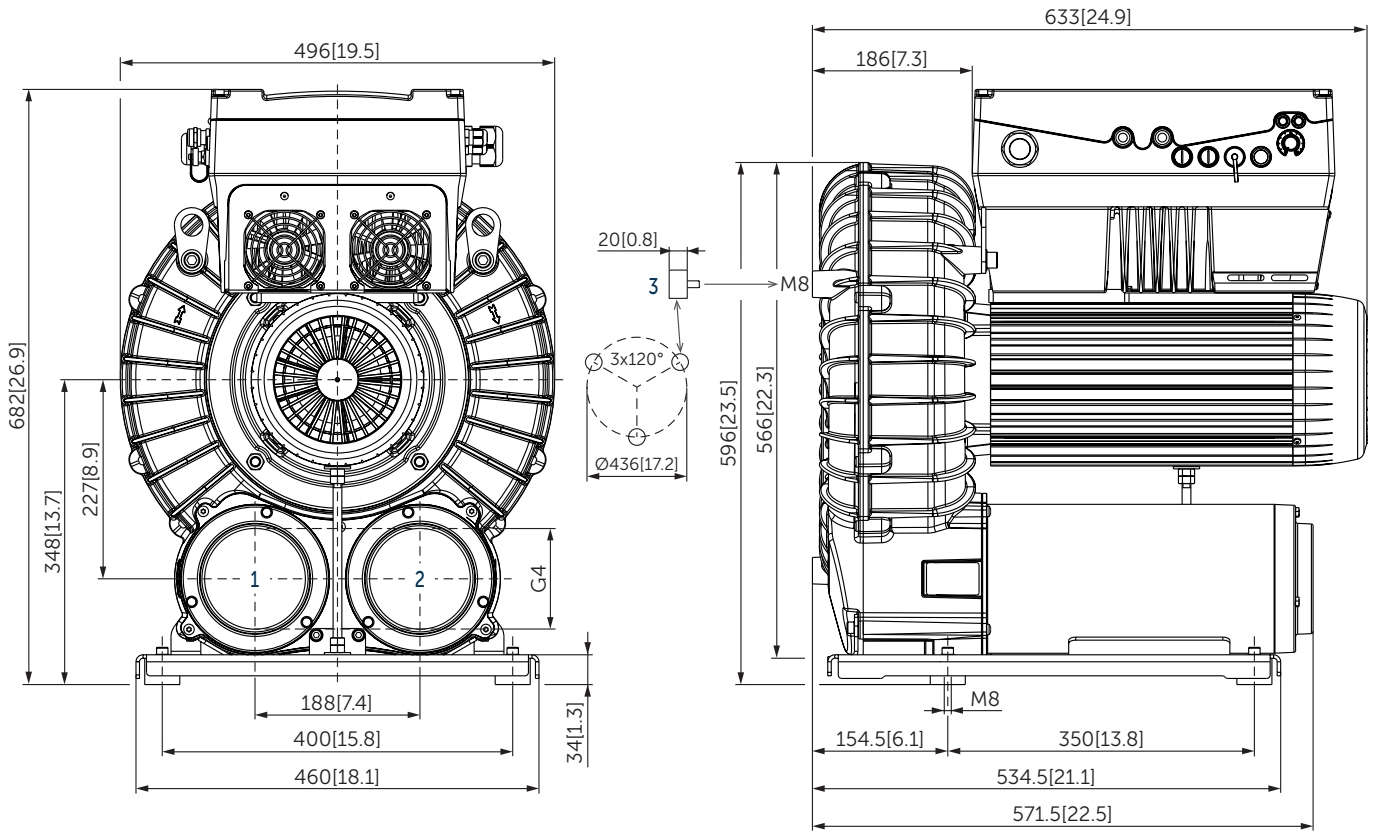

- 1 Vacuum connection (G4)
- 2 Pressure connection (G4)
- 3 Rubber buffer position (optional)
- Dimensions in mm [inch]

Suction air rate	Vacuum relative	Frequency	Emission sound pressure level ¹⁾	Weight	Frequency inverter VAU11-22/3	A
m ³ /h max.	mbar max.	Hz	dB(A) @ -217 mbar (53 Hz)	kg	11–22 kW 400–480 V ±10% 50/60 Hz	A max.
1180	-336	10–80	74.5	120		35

¹⁾ According to DIN EN ISO 11203, accuracy class of measurement: class 2, extended measurement uncertainty: 3 dB
1 m [39.4 inch] distance, at medium load, both connection sides piped

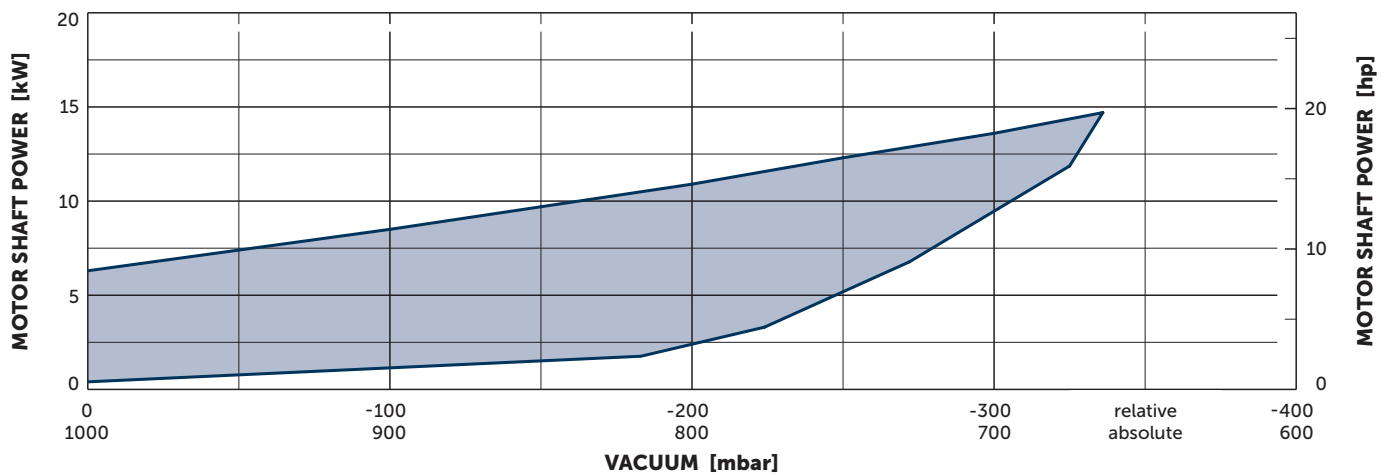
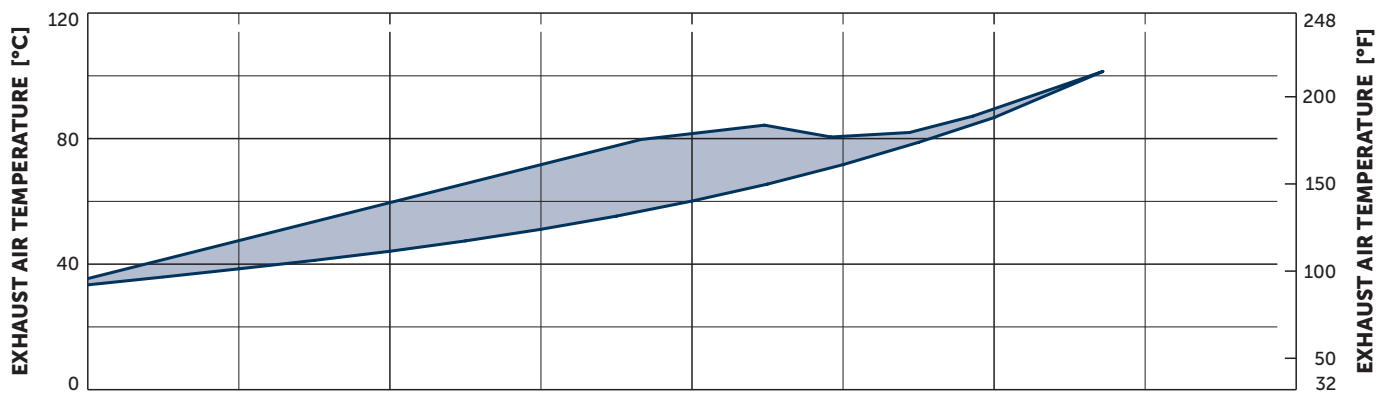
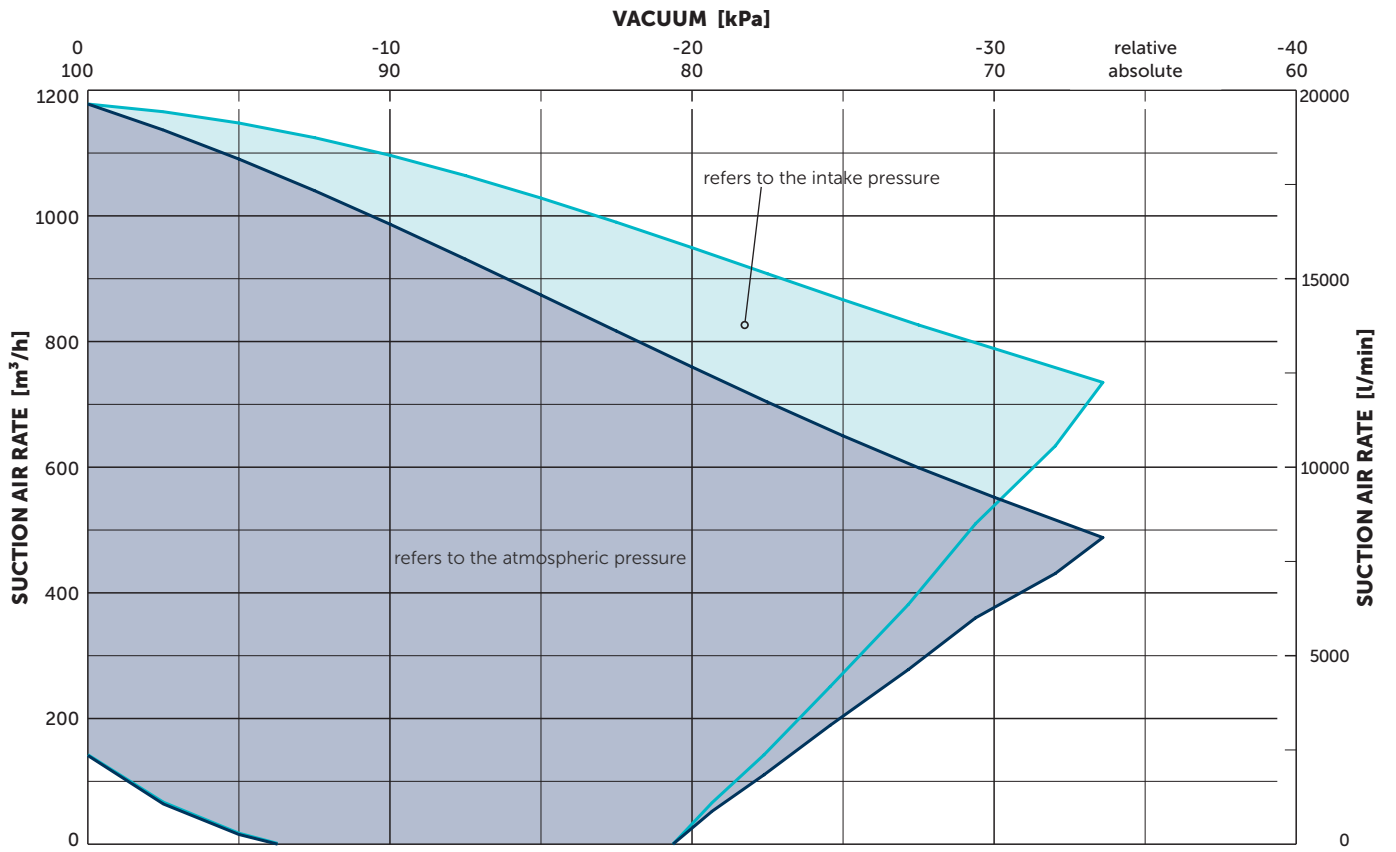

Reference data (atmosphere): 1000 mbar (100 kPa), 20°C (68°F)
 Tolerance: ±10%
 Temperature: Ambient air -10°C ... 40°C (14°F ... 104°F), Inlet air 0°C ... 40°C (32°F ... 104°F)



MAKE IT BECKER.